

Connectors M 27



Housings

page 98



Inserts

page 99

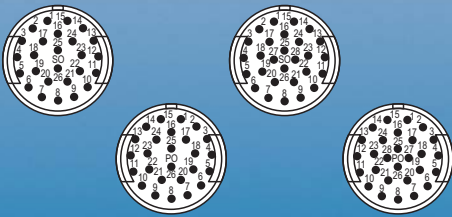

Accessories

page 101



M 27 Signal Connectors

Mechanical Data	Materials and Technical Data
Housing	Copper-Zinc alloy Die Casting
Housing surface	Nickel plated other surface upon request
Inserts (for contacts)	Thermoplastic Polyamid PA 6 (Nylon 6/6), PBT Fire protection class V-0
Contacts	Brass Alloy
Contact surface at point of contact	Nickel and gold plated (0,25µm Au)
Minimum mating cycles	> 1000
Seals / O-Rings	Buna-N standard optional Viton® (Viton is a registered trademark of DuPont)
Temperature range	-40°C – 125°C (-40°F – 257°F)
Type of contacts	Crimp, solder, dip-solder (PCB)
Protection	IP 67 / IP 69 K per EN 60 529 (connected), NEMA 4x
Cable diameter range	7 – 17 mm (.28 – .55")

Electrical Data			
Number of positions		26	28
Number of contacts		26	28
Contact-Ø [mm]		1	1
Nominal current ¹⁾ [A]		8	8
Nominal voltage ²⁾ [V~]		150	150
Test voltage (Breakdown voltage) ³⁾ [V~]		1500	1500
Insulation resistance [MΩ]		> 10 ¹²	> 10 ¹²
Max. contact resistance [mΩ]		3	3
Degree of Protection ⁴⁾		3	3

¹⁾, ²⁾, ³⁾, ⁴⁾ See Technical Informations page 14

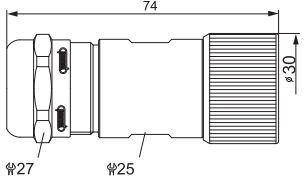

Signal Connectors M 27 / Housing

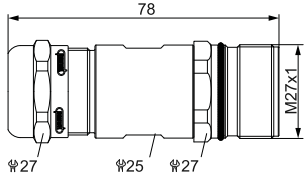
Straight Connector, Female Thread		Cable-Ø	Part Number
		7 – 12 mm (.28 - .47")	7.110.500.000
		11 – 17 mm (.43 - .67")	7.110.600.000
		Contacts and inserts page 99 • Assembly instructions page 103	

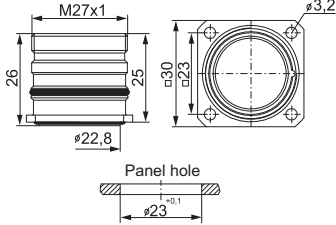

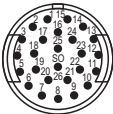
Straight Connector, Male Thread		Cable-Ø	Part Number
		7 – 12 mm (.28 - .47")	7.210.500.000
		11 – 17 mm (.43 - .67")	7.210.600.000
		Contacts and inserts page 99 • Assembly instructions page 103	

Panel Connector, Male Thread, front mounting		Type	Part Number
		4 x holes 3,2 mm	7.410.700.000
		Contacts and inserts page 99 • Assembly instructions page 104	

Type	Part Number	Part Number	Inserts 26-pole
Pinout clockwise	Pins	Sockets	
Insert with solder contacts	7.001.926.103	7.001.926.104	 Insert pin mating view
Insert without contacts	7.003.926.101	7.003.926.102	
Insert with dip solder contacts Length 3,5 mm	7.001.926.107		 Insert socket mating view
Insert with dip solder contacts Length 10 mm	7.001.926.127		
<p>The correct dimension of a connector with dip solder contacts depends on the particular type of housing.</p>			
Contacts page 100			



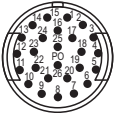

Type	Part Number	Part Number	Inserts 28-pole
Pinout clockwise	Pins	Sockets	
Insert with solder contacts	7.001.928.103	7.001.928.104	 Insert pin mating view
Insert with dip solder contacts Length 3,5 mm	7.001.928.107		
Insert with dip solder contacts Length 10 mm	7.001.928.127		 Insert socket mating view
<p>The correct dimension of a connector with dip solder contacts depends on the particular type of housing.</p>			
Contacts page 100			

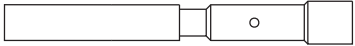
Signal Connectors M27 / required contacts

Contact Arrangement	Number of Poles	Required Contacts
	26	26 x 1 mm
	28	28 x 1 mm

Contacts	Type	Crimp Range	Part Number
	Crimp pin 1 mm, machined0,14 – 1 mm ² (AWG 26 – 17)7.010.971.001
	Crimp socket 1 mm, machined	...0,14 – 1 mm ² (AWG 26 – 17)7.010.971.002

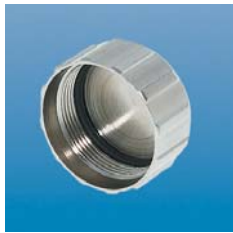
Crimp Tool Settings see page 102

Type	Part Number	Accessories
Plastic protective cap for connectors with male thread7.000.980.167 for connectors with female thread7.000.980.168		
Brass protective cap for connectors with female thread7.010.900.169 Brass protective cap with chain for connectors with female threadLength 70 mm7.010.9S0.707		
Brass protective cap for connectors with male thread7.010.900.170 Brass protective cap with chain for connectors with male threadLength 70 mm7.010.9S0.708		
Crimp tool for manual crimping of machined crimp contacts. Works with contacts for power or signal M27.7.000.900.901 See page 118/119 for crimp tool instructions and page 102 proper setting		
Assembly tool7.010.900.110		

Crimp Tool for Signal Connectors M27

Crimp Tool Setting for HUMMEL Crimp Contacts (Crimp Tool 7.000.900.901)

Part Number	Crimp Contact	Cross Section mm ²	AWG	Crimp Tool Setting mm	Locator Setting
7.010.971.001	Crimp pin (signal) 1 mm	0,14	26	0,70	1
		0,25	24	0,80	1
		0,34	22	0,88	1
		0,50	20	0,95	1
		0,75	18	1	1
		1	17	1,03	1
7.010.971.002	Crimp socket (signal) 1 mm	0,14	26	0,70	4
		0,25	24	0,80	4
		0,34	22	0,88	4
		0,50	20	0,95	4
		0,75	18	1	4
		1	17	1,03	4

Straight Connector, Female Thread

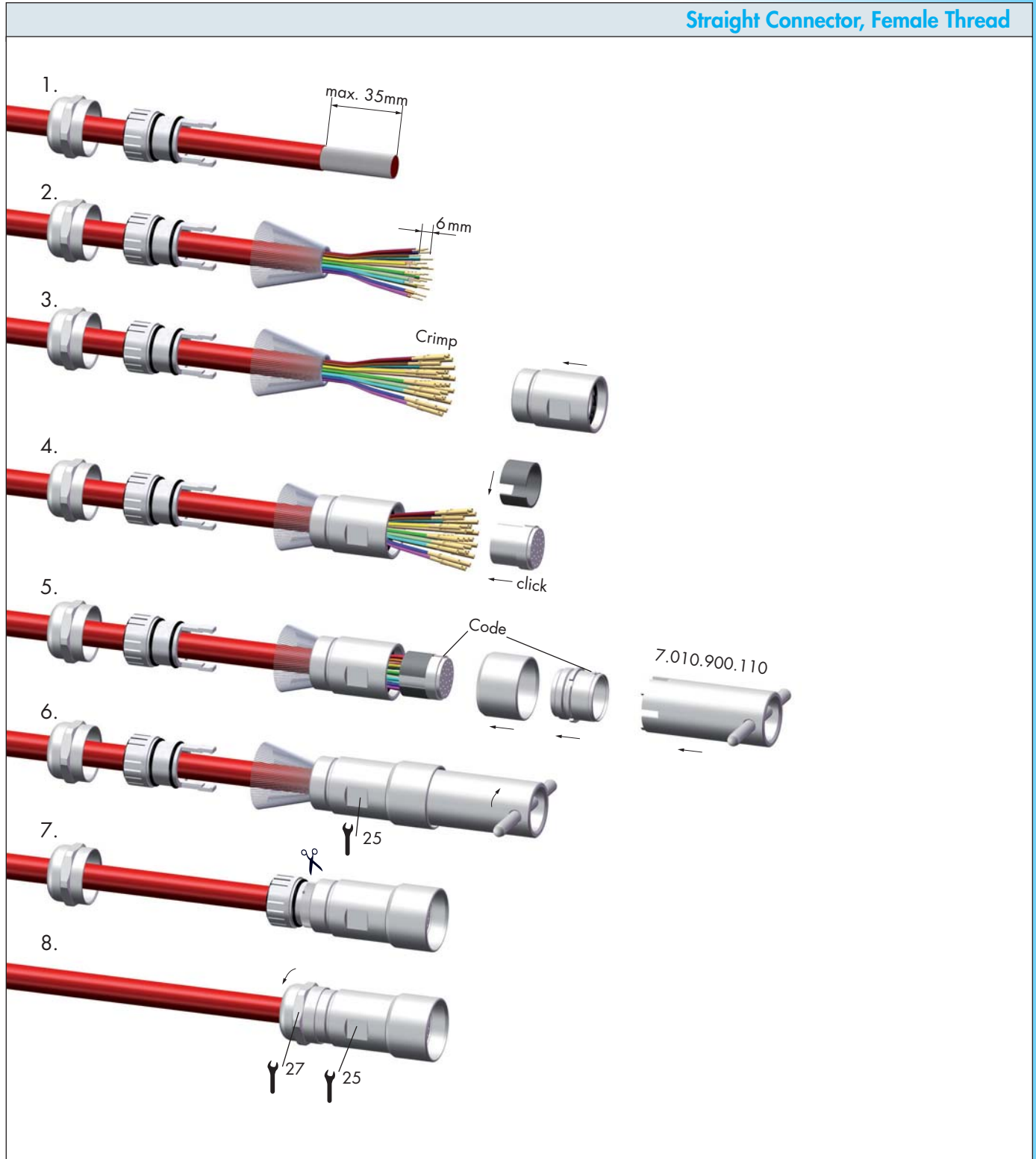

Panel Connector

